

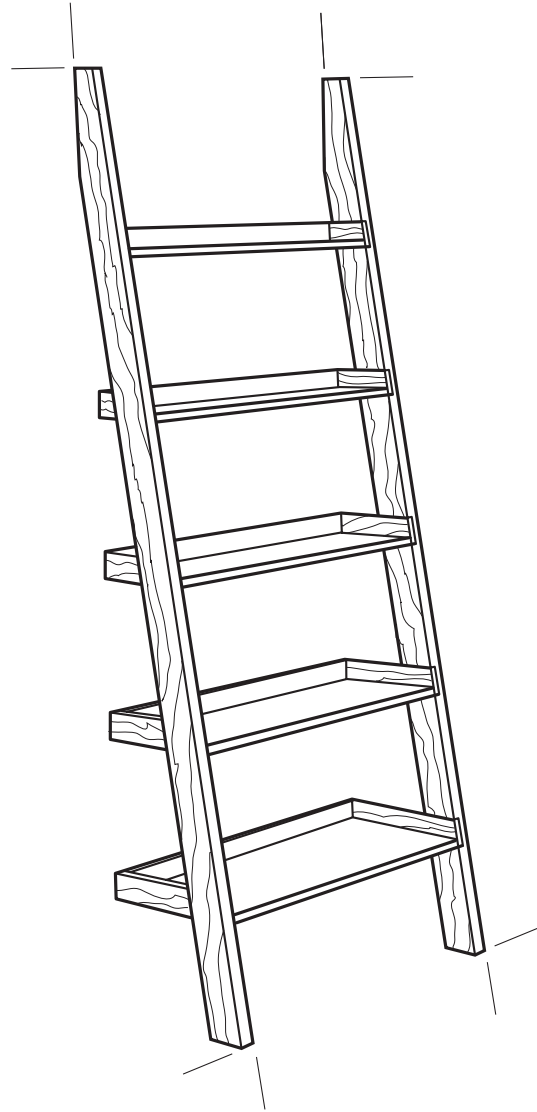

WOODWORKS: INTERMEDIATE PROJECT 2004-2005 LEANING TOWER OF SHELVES



This stylish but sturdy shelf unit will neatly hold your personal things—and you can build it in a day!

It may look lightweight and easy to topple, but don't be fooled. This shelf tower is a real workhorse. Whether you make it for holding your books or for showcasing family treasures, the basic construction is the same, and its open design won't overpower any room. All the materials can be purchased in home centers or lumberyards. The only special tools you'll need are a power miter box for crisp angle cuts and an air-powered brad nailer (or a hammer and finish nails could substitute) for quick assembly and almost invisible joints. And you'll have to rustle up an old clothes iron for applying oak edge-banding material. Once you've gathered the materials, you can build the shelf unit in an afternoon.

In this intermediate-level project, you'll gain experience in laying out and making angle cuts, fastening and finishing edge veneer, assembling a piece with several clamps, and working with an air nailer. And after you build it, you'll learn more about applying stains and finishes to enhance the wood's natural beauty and ensure that it's well protected.

TOOLS REQUIRED

Hand Tools

- Veneer edge trimmer
- Sanding block
- Clamps

Power Tools

- Table saw
- Jigsaw
- Miter saw
- Orbital sander
- Air-powered brad nailer (or hammer and nails)
- Clothes iron

Miscellaneous

- Safety glasses
- Framing square
- 120-, 150- and 220-grit sandpaper
- Clean, lint-free cloths
- Respirator
- Gloves for finishing
- Mineral spirits (for oil-based finishes)
- Water-filled metal container with tight-fitting lid
- Minwax® Wood Finish™ Stain Brush or other good quality, natural bristle brush (for oil-based stains and finishes)
- Minwax® Polycrylic® Brush or other good quality, synthetic bristle brush (for water-based stains and finishes)
- Minwax® Stainable Wood Filler
- Carpenter's glue

SHOPPING LIST

Item	Quantity
3/4" oak plywood	1/2 sheet (4' x 4')
1" x 3" x 8' oak boards	3
1" x 4" x 8' oak boards	4
7/8" oak iron-on veneer	1 package (25')
1-1/4" finish brads	1 small box
Foot pads (3/4" round, self-adhesive, non-skid pads)	1 package

Recommended Wood – Oak

Alternate Wood – Cherry or maple

We built our unit with red oak and oak veneer plywood, but the beauty of this project is that any wood species will work. One note when buying boards: Use a tape measure to check the “standard” dimensions of 1" x 3" and 1" x 4" boards. With hardwoods, they sometimes vary in width and thickness. Also check the two full-length 1" x 4" boards you plan to use as the uprights to be sure they're straight, with no warps or twists. And always examine the ends, edges and surfaces for blemishes or rough areas that won't easily sand out.

WOOD FINISHING PRODUCTS

Recommended Finish

Prep: Minwax® Pre-Stain Wood Conditioner (if using soft or porous wood)

Stain: Minwax® Wood Finish™; for a unique, rich color, make a 50/50 mix of Wood Finish™ English Chestnut and Wood Finish™ Sedona Red (or choose from 20 Minwax® Wood Finish™ colors)

Finish: Minwax® Wipe-On Poly Satin

Alternate Finish

Prep: Minwax® Water-Based Pre-Stain Wood Conditioner

Stain: Minwax® Water-Based Wood Stain Island Water (or a Minwax® Water-Based Wood Stain of your choice, available in 6 wood tones, a White Wash Pickling Stain, 60 custom-mixed colors, and 8 bold Accents™ colors)

Finish: Minwax® Polycrylic® Protective Finish Satin

CUTTING LIST

Key	Pcs.	Size & Description
A	1	3/4" x 3-3/8" x 30-1/2" oak plywood (shelf base)
B	1	3/4" x 5-3/4" x 30-1/2" oak plywood (shelf base)
C	1	3/4" x 8-3/16" x 30-1/2" oak plywood (shelf base)
D	1	3/4" x 10-5/8" x 30-1/2" oak plywood (shelf base)
E	1	3/4" x 13" x 30-1/2" oak plywood (shelf base)
F	2	3/4" x 2-1/2" x 4-3/8" oak (shelf A sides; front end only cut at 10 degrees)
G	2	3/4" x 2-1/2" x 6-3/4" oak (shelf B sides; front end only cut at 10 degrees)
H	2	3/4" x 2-1/2" x 9-3/16" oak (shelf C sides; front end only cut at 10 degrees)
I	2	3/4" x 2-1/2" x 11-5/8" oak (shelf D sides; front end only cut at 10 degrees)
J	2	3/4" x 2-1/2" x 14" oak (shelf E sides; front end only cut at 10 degrees)
K	5	3/4" x 2-1/2" x 30-1/2" oak (shelf backs for A-E)
L	2	3/4" x 3-1/2" x 14-1/2" oak shelf cleats (cut both ends with 10-degree angles)
M	8	3/4" x 3-1/2" x 11-3/4" oak shelf cleats (cut both ends with 10-degree angles)
N	2	3/4" x 3-1/2" x 10" oak shelf cleats (cut both ends with 10-degree angles)
O	2	3/4" x 3-1/2" x 84" oak uprights (cut both ends with 10-degree angles)

BEFORE YOU BEGIN

Good craftsmanship begins and ends with good work habits, so make the following steps part of your routine workshop practice. If you have any doubts or questions about how to proceed with a project, always discuss them with your shop instructor.

- Carefully and fully review plans and instructions before putting a tool to the project lumber.
- Work sensibly and safely. Wear safety goggles when doing work that creates flying chips and sawdust; wear the appropriate respirator whenever making sawdust or working with thinners or other solvents.
- At the end of every work session, clean up your shop area and put away all portable tools.

CUTTING AND ASSEMBLY PROCEDURE

1. Use a table saw to cut the plywood shelves (A, B, C, D, E) from the 3/4" plywood. Note that there are five different shelf depths.
2. Clamp each shelf with the best edge facing up. Sand it lightly with 150-grit paper wrapped around a sanding block. Preheat a clothes iron to the "cotton" setting and run it over the top of the edge-banding veneer, positioning the veneer so it extends beyond all the plywood edges (Fig. 2). Immediately after adhering it to the plywood, run a smooth object, such as a chisel handle, over the tape. Let each shelf edge cool for a minute before trimming and sanding the edges.
3. Cut the 1x4 uprights (O) to the length shown in the CUTTING LIST, using a power miter saw to make the angled cuts on the ends. Use a jigsaw to taper the tops of the uprights according to the dimensions shown in Fig. 1.
4. Use the miter saw to cut the shelf sides (F, G, H, I, J) to length. Leave the saw at the 10-degree setting in order to cut the angled front ends. Then return the saw to the right-angle setting and cut the sides to length. Next, cut the shelf backs (K) to length.
5. Set the saw back to the 10-degree setting and cut the cleats (L, M, N) to length. **Note:** Leave the top cleats long and cut them to exact fit during assembly. To speed finishing, use an orbital sander with 120- and 150-grit sandpaper to sand all the pieces before assembly.
6. To begin assembly, lay out both uprights and all cleats to ensure that the angles are correct so the shelves will be level when the unit leans against a wall. Then glue and nail the first cleat flush with the base of each upright, using five or six 1-1/4" brads on each cleat. Work your way up using spacers made from a 1x3 (Fig. 3). Make sure the spacer is the exact width as the shelf sides. Set the assembled uprights aside to dry.
7. For shelf assembly, first glue and nail on the shelf backs. Next, apply the sides with glue and nails.

FINAL ASSEMBLY

8. For final assembly, clamp the shelves to one upright as shown in Fig. 4. Apply glue to the ends of the shelves, position the second upright on top flush with the front edges of the shelves, then sink four 1-1/4" brads into each shelf from the upright side. Carefully turn the unit over and repeat the process to attach the second upright. Work quickly so

the glue doesn't set. Lift the ladder shelf and place it upright against a wall. Check it with a framing square and flex it if necessary to square it up and to make sure that the uprights rest flat against the floor and wall (assuming your floor is level). Attach and tighten three bar clamps across the unit, aligned with the top, middle and bottom shelves, until the glue dries.

9. The shelf is highly stable as designed, but once you've stained and finished it, you can add self-adhesive foam gripping pads to the bottom of the uprights. You can also fasten the top of the uprights to the wall using small angle brackets and plastic screw anchors.

STAINING AND FINISHING

Woodworker's Tip: *Though you may be tempted to cut short your sanding, preparation and application time, don't do it. These tasks are very important steps in obtaining a high-quality finish. Remember, it is the finish, just as much as the fit and smoothness of the parts that will have great bearing on how people judge your craftsmanship. To ensure an excellent result, follow the steps listed in this section and also the instructions the finish manufacturer puts on its products.*

FINISHING TIPS

- Test the stains and finishes you are planning to use on scraps of wood. On the back of the scrap, mark the stain/finish combination and the type of wood. Allow all samples to dry thoroughly before making your final finish selection. Save your samples for quick reference on future projects.
 - All stains and finishes must be allowed to dry thoroughly between coats. Remember that drying times can vary due to humidity and other climatic conditions.
 - If you have some leftover stain or finish, wipe the can rim so that stain or finish in the rim won't dry out and prevent the lid from forming a tight seal.
 - Brushes used for oil-based finishes must be cleaned with mineral spirits; for water-based products, such as Minwax® Water-Based Wood Stains or Minwax® Polycrylic® Protective Finish, clean brushes with warm water and soap.
10. Sand the shelf units with 150-grit paper, then move up to 220-grit to complete the pre-finish smoothing. Use an orbital sander to remove any marks or scratches, then lightly sand with-the-grain strokes by hand. Dust off the piece and wipe it carefully with a clean, lint-free cloth lightly dampened with mineral spirits.
 11. Do the staining in two steps, starting on the interior surfaces and then moving to the exterior surfaces.

NOTE: If you choose a softwood, such as pine, or a porous hardwood, like maple, you'll need to prepare it for staining with a coat of Minwax® Pre-Stain Wood Conditioner or Minwax® Water-Based Pre-Stain Wood Conditioner if you're using a water-based stain. Applying the conditioner will help to ensure even absorption of stain and prevent blotchiness that can occur with some soft or porous woods. Following the directions on the can, simply brush the conditioner over all the wood and allow it to penetrate for 5 to 15 minutes. Then remove excess conditioner with a clean, dry cloth.

Recommended Finish

For this project, we've chosen a 50/50 mix of Wood Finish™ English Chestnut and Wood Finish™ Sedona Red for a unique, rich color. Mixing is a fun way to experiment with tones and colors. It allows you to creatively express your own personal taste and style, and is often a technique that decorators and professional contractors use.

12. Apply the Minwax® Wood Finish™ you've chosen to the interior surfaces using a good quality, natural bristle brush or a clean, lint-free cloth. The brush will help you get the stain into the many inside corners and other tight spots. Allow the Wood Finish™ to set for about 5 to 15 minutes, then wipe off any excess. Repeat for the exterior surfaces. To achieve a deeper color, you may apply a second coat after 4 to 6 hours, repeating the application directions for the first coat. Allow the stain to dry for 24 hours before applying the protective clear finish.

13. Apply Minwax® Wipe-On Poly following the directions on the can. Shake the can thoroughly. Apply a liberal amount of Wipe-On Poly to a clean, soft, lint-free cloth, and rub into the wood. Allow the first coat to dry overnight.

14. The following day, sand all surfaces very lightly with 220-grit or finer sandpaper or very fine (000) steel wool using with-the-grain strokes. Thoroughly wipe off all surfaces with a clean, soft cloth. Apply a second coat of Minwax® Wipe-On Poly and set the piece aside to dry overnight.

15. The next day, sand all surfaces lightly with 220-grit or finer sandpaper or very fine (000) steel wool. Thoroughly wipe off the piece with a soft cloth and apply a third and final coat of Wipe-On Poly. Allow the finish to cure for several days and then you'll be ready to start stacking the shelves.

Alternate Finish

16. Before applying Minwax® Water-Based Wood Stain to a hardwood or softwood, apply Minwax® Water-Based Pre-Stain Wood Conditioner following the directions on the can. After 1 to 5 minutes, wipe off all excess conditioner using a clean, lint-free cloth. Wait 15 to 30 minutes, then use 220-grit or finer sandpaper to sand off any "whiskers" raised by the conditioner. Dust off the piece and wipe it down with a soft, lint-free cloth. Proceed to staining within 2 hours.

17. Do the staining in two steps, starting on the interior surfaces and then moving to the exterior surfaces. Apply the Minwax® Water-Based Wood Stain you've chosen to the interior surfaces using either a nylon/polyester brush or a soft cloth. Allow stain to penetrate no longer than 3 minutes. While stain is still wet, wipe off all excess with a clean cloth that's been lightly dampened with stain. To achieve a deeper color, you may apply a second coat after 4 to 6 hours, repeating the application directions for the first coat. Allow the piece to dry overnight before applying the protective clear finish.

Woodworker's Tip: Minwax® Water-Based Wood Stain is available in 6 wood tones, a White Wash Pickling Stain, 60 custom-mixed colors, and 8 bold Accents™ colors. This means that you are not limited to just traditional wood colors (pine, oak, walnut, etc.). Instead, you can pick and apply a color to complement the décor of the room in which the shelves will be.

For this reason, make sure you look over all of the Minwax® color charts before making your final selection.

18. After allowing the piece to dry overnight, apply Minwax® Polycrylic® Protective Finish following the directions on the can. Stir the can contents thoroughly before starting and periodically repeat the stirring during your work session.

19. Working a small area at a time to maintain a wet edge, apply the first coat. Work quickly and make the final strokes in each newly finished section using with-the-grain brushstrokes.

20. Allow the finish to dry a minimum of 2 hours. Then sand lightly with 220-grit or finer sandpaper wrapped around a soft backup block. Thoroughly dust off and wipe all surfaces with a cloth lightly dampened with water.

21. Repeat steps 17 and 18 to apply the second and final coat.

PRODUCT SAFETY

For your safety and the safety of those you work with, always read the safety warnings, which manufacturers print on their labels, and follow them to the letter. Typical safety advice and instructions will contain information such as the following:

WARNING! Removal of old paint by sanding, scraping or other means may generate dust or fumes that contain lead. Exposure to lead dust or fumes may cause brain damage or other adverse health effects, especially in children or pregnant women. Controlling exposure to lead or other hazardous substances requires the use of proper protective equipment, such as properly fitted respirator (NIOSH approved) and proper containment and cleanup. For more information, call the National Lead Information Center at 1-800-424-LEAD (in US) or contact your local health authority.

When using oil-based wood finishing products:

CAUTIONS: CONTAINS ALIPHATIC HYDROCARBONS. Contents are COMBUSTIBLE. Keep away from heat and open flame. **VAPOR HARMFUL.** Use only with adequate ventilation. To avoid overexposure, open windows and doors or use other means to ensure fresh air entry during application and drying. If you experience eye watering, headaches, or dizziness, increase fresh air, or wear respiratory protection (NIOSH approved), or leave the area. Avoid contact with eyes and skin. Wash hands after using. Keep container closed when not in use. Do not transfer contents to other containers for storage.

FIRST AID: In case of eye contact, flush thoroughly with large amounts of water for 15 minutes and get medical attention. For skin contact, wash thoroughly with soap and water. In case of respiratory difficulty, provide fresh air and call physician. If swallowed, do not induce vomiting. Call Poison Control Center, hospital emergency room, or physician immediately.

NOTICE: Reports have associated repeated and prolonged occupational exposure to solvents with permanent brain and nervous system damage. Intentional misuse by deliberately concentrating and inhaling contents may be harmful or fatal.

WARNING: This product contains a chemical known to the State of California to cause cancer and birth defects or other reproductive harm.

DO NOT TAKE INTERNALLY. KEEP OUT OF REACH OF CHILDREN.

When using water-based wood finishing products:

CAUTIONS: Use Only With Adequate Ventilation. To avoid overexposure, open windows and doors or use other means to ensure fresh air entry during application and drying. If you experience eye watering, headaches, or dizziness, increase fresh air, or wear respiratory protection (NIOSH approved), or leave the area. Avoid contact with eyes and skin. Wash hands after using. Keep container closed when not in use. Do not transfer contents to other containers for storage.

FIRST AID: In case of eye contact, flush thoroughly with large amounts of water. Get medical attention if irritation persists. If swallowed, get medical attention immediately.

WARNING: Contains Alkyl propanols, ethylene glycol, n-methyl pyrrolidone. **VAPOR HARMFUL.** Use only with adequate ventilation. To avoid overexposure, open windows and doors or use other means to ensure fresh air entry during application and drying. If you experience eye watering, headaches, or dizziness, increase fresh air, or wear respiratory protection (NIOSH approved), or leave the area. Avoid contact with eyes and skin. Wash hands after using. Keep container closed when not in use. Do not transfer contents to other containers for storage.

DO NOT TAKE INTERNALLY.

FIRST AID: In case of eye contact, flush thoroughly with large amounts of water for 15 minutes and get medical attention. For skin contact, wash thoroughly with soap and water. In case of respiratory difficulty, provide fresh air and call physician. If swallowed, call Poison Control Center, hospital emergency room, or physician immediately.

DELAYED EFFECTS FROM LONG-TERM OVEREXPOSURE.

Contains solvents which can cause permanent brain and nervous system damage. Intentional misuse by deliberately concentrating and inhaling contents may be harmful or fatal.

WARNING: This product contains a chemical known to the State of California to cause cancer and birth defects or other reproductive harm.

KEEP OUT OF REACH OF CHILDREN.

SAFE DISPOSAL OF RAGS AND WASTE.

Please be mindful of the safe way to dispose of rags and other waste. Rags, steel wool and other waste products soaked with oil finishes or solvents may spontaneously catch fire if improperly discarded. Place rags, steel wool and other waste immediately after use in a water-filled metal container. Tightly seal and dispose of the waste materials in accordance with local trash removal regulations. Be sure to keep the waste out of reach of children.

This project was adapted with permission from *The Family Handyman* magazine, Home Services Publications, Inc., an affiliate of Reader's Digest Association, Inc., Suite 700, 2915 Commers Drive, Eagan, MN 55121. ©Copyright 2004. All rights reserved. For subscriptions call toll-free: 1-800-666-3111.

FIG 1. SHELVES DETAILS

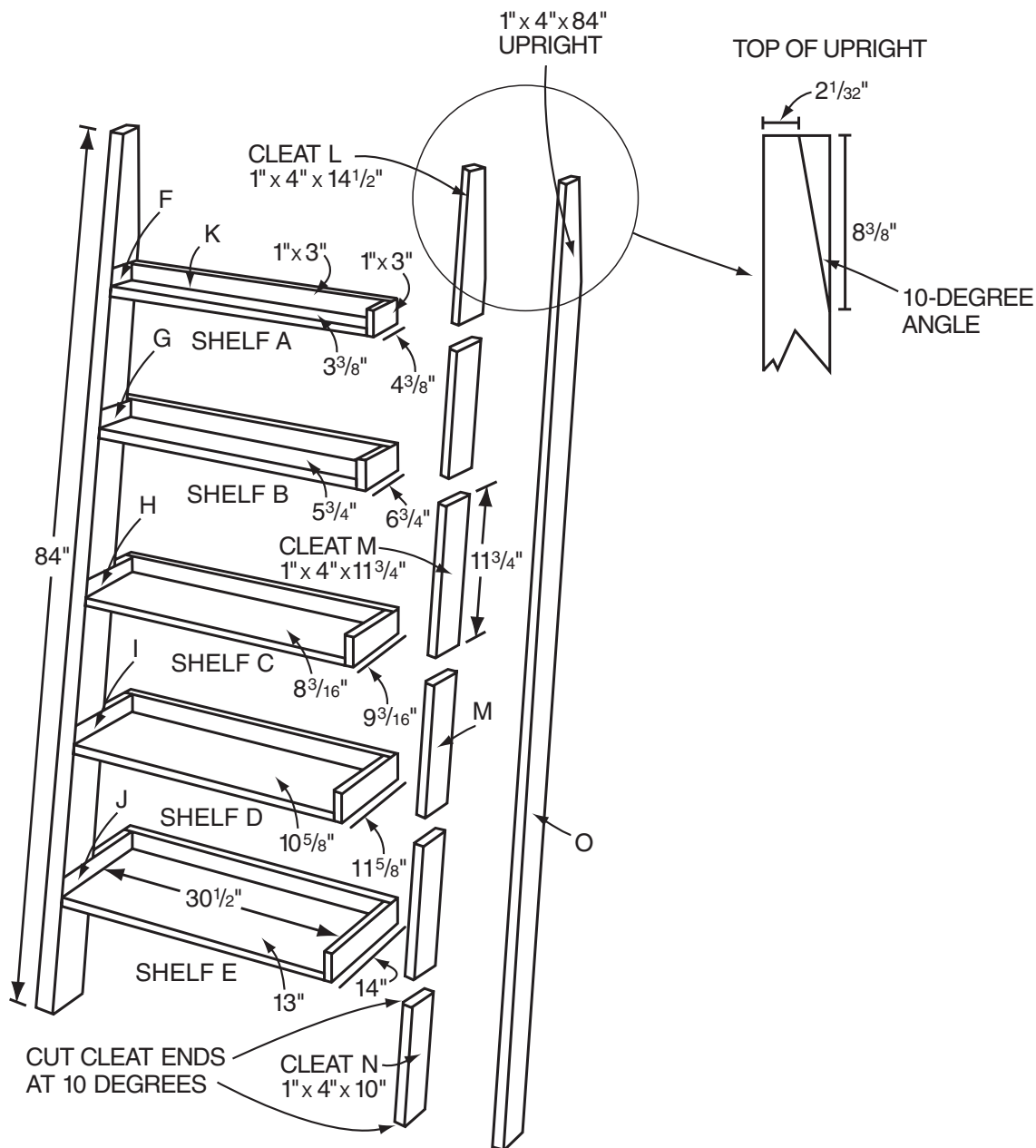

FIG 2. APPLYING THE OAK EDGE-BANDING VENEER

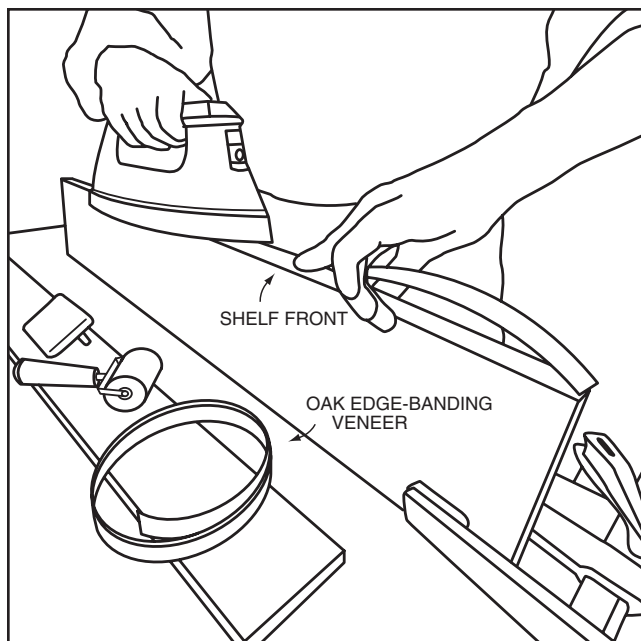

FIG 3. GLUE AND NAIL CLEATS

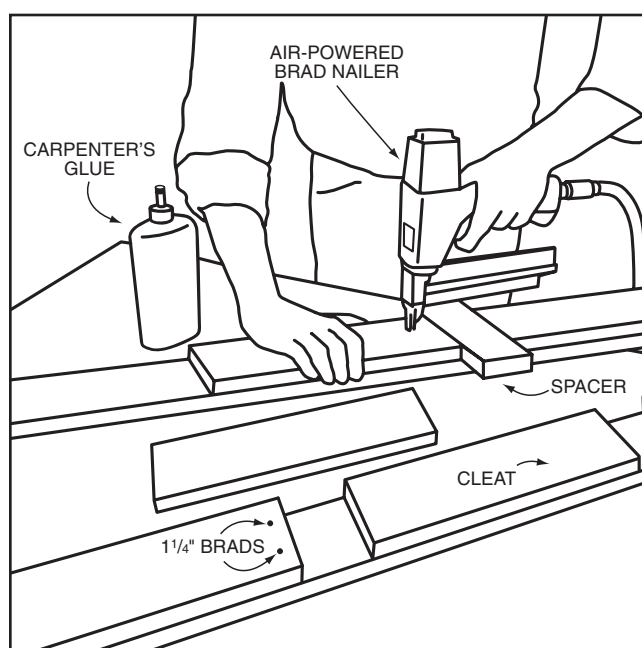

FIG 4. FINAL ASSEMBLY

